

Positive Temperature Coefficient (PTC) Data Sheet

Description

The 130V series provides radial resettable overcurrent protection with holding current from 0.1A to 1.35A. This series is suitable for applications with higher working voltage up to 130V.

Features

- Radial leaded devices.
- High voltage surge capabilities
- Flame retardant epoxy polymer insulating material meets UL94 V-0 requirement.
- Over-current protection
- Available in lead-free version.
- Operating Temperature: -40°C~+85°C
- Meets MSL level 1, per J-STD-020

Applications

- Printer and USB hub
- Security systems
- Network equipment
- Transformer and power adapter
- XDSL equipment
- Motor protection

Electrical Characteristics

Part Number	I _{hold} (A)	I _{trip} (A)	V _{max} (V _{AC})	I _{max} (A)	Pd typ. (W)	Maximum time to trip		Resistance	
						Current(A)	Times (S)	R _{min} (Ω)	R _{max} (Ω)
FTR130-100	0.10	0.20	130	20	0.40	0.50	5.0	9.0	18.0
FTR130-120	0.12	0.24	130	20	0.46	0.60	6.0	6.0	12.0
FTR130-160	0.16	0.32	130	20	0.50	0.80	7.0	3.5	7.5
FTR130-200	0.20	0.40	130	20	0.72	1.00	5.0	2.5	5.0
FTR130-250	0.25	0.50	130	20	0.90	1.25	5.0	1.9	3.8
FTR130-300	0.30	0.60	130	20	1.00	1.50	5.0	1.3	2.6
FTR130-400	0.40	0.80	130	20	1.30	2.00	5.0	0.9	1.8
FTR130-500	0.50	1.00	130	20	1.60	2.50	5.0	0.8	1.6
FTR130-650	0.65	1.30	130	10	1.70	3.25	8.0	0.5	1.0
FTR130-750	0.75	1.50	130	10	1.80	3.75	8.0	0.4	0.8
FTR130-900	0.90	1.80	130	10	2.10	4.50	8.0	0.3	0.6
FTR130-1100	1.10	2.20	130	10	2.40	5.50	9.0	0.3	0.5
FTR130-1350	1.35	2.70	130	10	2.80	6.75	10.0	0.2	0.4

·I_{hold}= Hold current: maximum current device will pass without tripping in 25°C still air.
 ·I_{trip}= Trip current: minimum current at which the device will trip in 25°C still air.
 ·V_{max}= Maximum voltage device can withstand without damage at rated current (I_{max})
 ·I_{max}= Maximum fault current device can withstand without damage at rated voltage
 ·Pd typ.= Typical power dissipated from device when in the tripped state at 23°C still air.
 ·R_{min}= Minimum resistance of device in initial (un-soldered) state.
 ·R_{max}= Maximum resistance of device in initial (un-soldered) state.

Test Procedures and Requirement

Items	Test Conditions	Accept/Reject Criteria
Resistance	In still air @25°C	$R_{min} \leq R \leq R_{max}$
Time to Trip	Specified current, V max , 25°C	$T \leq \text{max. Time to trip (T trip)}$
Hold Current	30 min, at Ihold	No trip
Trip Cycle Life	V max , I max , 100 cycle	No arcing or burning
Trip Endurance	V max , 24hours	No arcing or burning

Thermal Derating Chart – Ihold

Part Number	Ambient Operation Temperature									
	-40°C	-20°C	0°C	25°C	30°C	40°C	50°C	60°C	70°C	85°C
FTR130-100	0.150	0.135	0.12	0.100	0.09	0.08	0.07	0.06	0.05	0.04
FTR130-120	0.180	0.160	0.14	0.120	0.11	0.10	0.09	0.08	0.06	0.05
FTR130-160	0.225	0.210	0.19	0.160	0.15	0.13	0.12	0.10	0.09	0.06
FTR130-200	0.285	0.260	0.24	0.200	0.18	0.16	0.14	0.13	0.11	0.08
FTR130-250	0.345	0.330	0.30	0.250	0.23	0.21	0.18	0.16	0.14	0.10
FTR130-300	0.402	0.390	0.36	0.300	0.27	0.25	0.22	0.19	0.16	0.12
FTR130-400	0.550	0.520	0.48	0.400	0.36	0.33	0.29	0.25	0.22	0.16
FTR130-500	0.670	0.650	0.60	0.500	0.45	0.41	0.36	0.32	0.27	0.21
FTR130-650	0.895	0.860	0.77	0.650	0.59	0.53	0.47	0.41	0.35	0.27
FTR130-750	1.010	0.990	0.89	0.75	0.68	0.62	0.54	0.47	0.41	0.31
FTR130-900	1.120	1.180	1.07	0.90	0.81	0.74	0.65	0.57	0.49	0.37
FTR130-1100	1.455	1.440	1.31	1.10	0.99	0.90	0.79	0.69	0.59	0.45
FTR130-1350	1.795	1.780	1.61	1.35	1.22	1.11	0.97	0.85	0.73	0.55

Dimensions

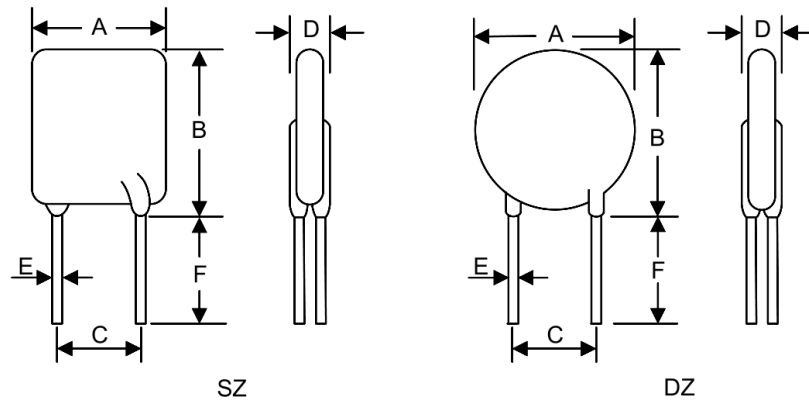

Part Number	Dimensions (mm)						Style.
	A	B	C	D	E	F	
	Max.	Max.	±0.6	Max.	Typ.	Min.	
FTR130-100	8.3	10.7	5.1	3.8	0.5	7.6	DZ
FTR130-120	8.3	10.7	5.1	3.8	0.5	7.6	DZ
FTR130-160	8.5	12.5	5.1	3.8	0.5	7.6	DZ
FTR130-200	9.6	17.4	5.1	3.8	0.6	7.6	SZ
FTR130-250	9.6	17.4	5.1	3.8	0.6	7.6	SZ
FTR130-300	9.6	17.5	5.1	3.8	0.6	7.6	SZ
FTR130-400	11.4	19.5	5.1	3.8	0.6	7.6	SZ
FTR130-500	11.5	21.7	5.1	3.8	0.6	7.6	SZ
FTR130-650	14.0	21.7	5.1	3.8	0.8	7.6	SZ
FTR130-750	14.0	21.7	5.1	3.8	0.8	7.6	SZ
FTR130-900	14.0	21.7	5.1	3.8	0.8	7.6	SZ
FTR130-1100	14.0	16.2	5.1	3.8	0.8	7.6	DZ
FTR130-1350	13.2	25.0/23.0	5.1	3.8	0.8	7.6	SZ/DZ

Marking Code

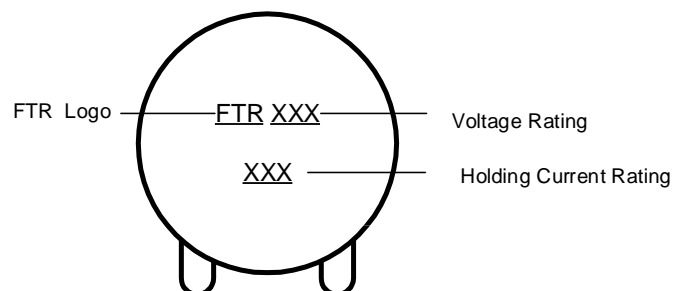

Recommended Soldering Conditions

Wave Soldering Recommendation Parameters

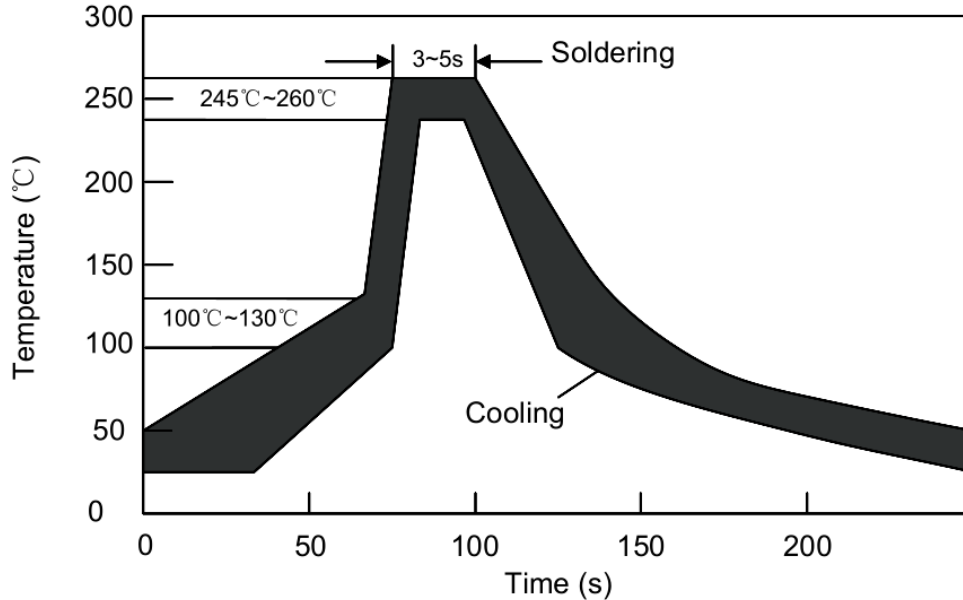

Items	Conditions
Pre-Heating Zone	Refer to the condition recommended by the flux manufacturer. Max. ramping rate should not exceed 4°C/Sec.
Soldering Zone	Max. solder temperature should not exceed 260°C Time within 5°C of actual Max. solder temperature within 3 - 5 seconds Total time from 25°C room to Max. solder temperature within 5 minutes including Pre-Heating time
Cooling Zone	Cooling by natural convection in air. Max. ramping down rate should not exceed 6°C/Sec.

Manual Soldering Recommendation Parameters

Items	Conditions
Soldering condition	The highest power of the manual soldering iron should be 30W or less, soldering temperature should not be higher than 280°C.
Soldering time	The soldering time should be kept within 3 seconds, otherwise it might cause insulation layer cracking, and increased part resistance.
Soldering position	The distance on the leads between the soldering point and bottom of the PPTC body should be equal or greater than 4mm.
Other	The soldering iron should not contact the PPTC body except the leads. If the soldering conditions are kept to lower temperature, less time and larger distance, the outcome of the soldering will be better.

Partnumber code

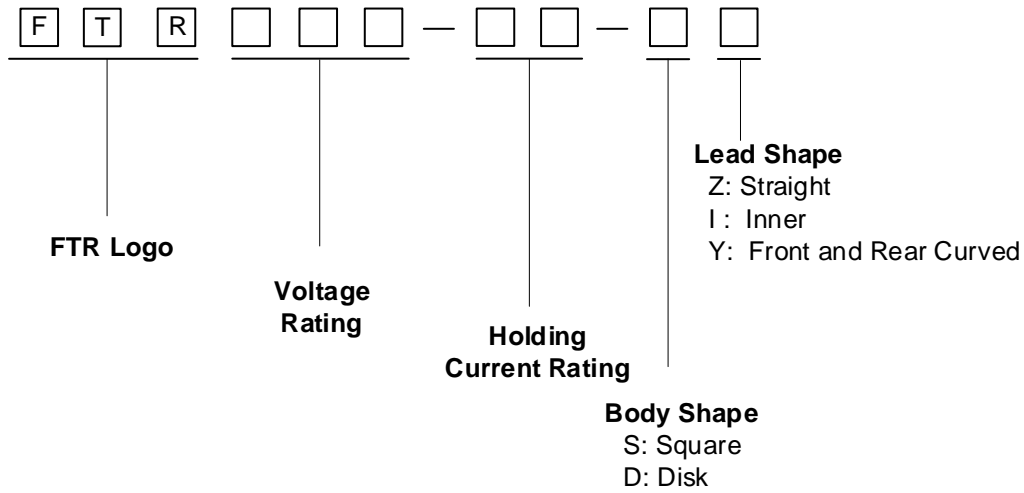

Environmental Specifications

Operating / Storage temperature	-40°C to +85°C
Maximum Device Surface Temperature in Tripped State	125°C
Passive Aging	+85°C, 1000 hours ±5% typical resistance change
Humidity Aging	+85°C, 85%RH, 1000 hours ±5% typical resistance change
Thermal Shock	+85°C to -40°C 10 times 30% typical resistance change
Solvent Resistance	MIL-STD-202, Method 215 No change
Moisture Level Sensitivity	Level 1, J-STD-020

Mechanical Specifications

Tensile strength	1.0Kgf, 10 seconds, No visible damage
Bending strength	0.5Kgf, 90°, 3 times, No visible damage
Vibration	Freq: 10-55Hz, Amp: 0.75mm, 1min; No visible damage

Packaging

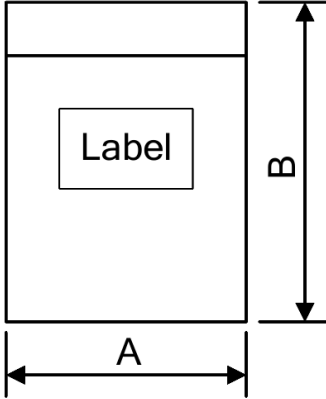
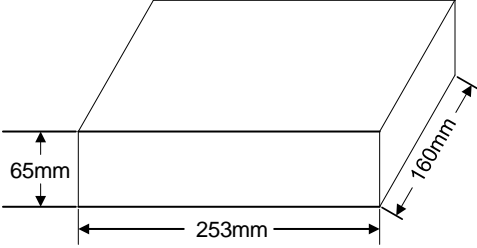
Bag	Part Number	Dimension AxB (mm)	Quantity
	FTR130-100	120x150	1000pcs/bag 4000pcs/box
	FTR130-120		
	FTR130-160		
	FTR130-200		
	FTR130-250		
	FTR130-300	150x200	
	FTR130-400	120x150	500pcs/bag 2000pcs/box
	FTR130-500		
	FTR130-650		
	FTR130-750	150x200	
	FTR130-900		
	FTR130-1100		
	FTR130-1350		