

Positive Temperature Coefficient (PTC) Data Sheet

Description

The 500V series provides radial resettable overcurrent protection with holding current from 0.11A to 0.16A. This series is suitable for applications with higher working voltage up to 500V.

Features

- Radial leaded devices.
- High voltage surge capabilities
- Flame retardant epoxy polymer insulating material meets UL94 V-0 requirement.
- Over-current protection
- Available in lead-free version.
- Operating Temperature: -40°C~+85°C
- Meets MSL level 1, per J-STD-020

Applications

- Powered supplies
- Security systems
- Network equipment
- IT equipment
- XDSL equipment
- Motor protection

Electrical Characteristics

Part Number	I _{hold} (A)	I _{trip} (A)	V _{max} (V _{AC})	I _{max} (A)	Pd typ. (W)	Maximum time to trip		Resistance	
						Current(A)	Times (S)	R _{min} (Ω)	R _{max} (Ω)
FTR600-110	0.11	0.22	500	3.0	1.0	1.0	5.0	6.0	18.0
FTR600-150	0.15	0.30	500	3.0	1.0	1.0	6.0	5.0	15.0
FTR600-160	0.16	0.32	500	3.0	1.0	1.0	7.5	4.0	12.0

- I_{hold}= Hold current: maximum current device will pass without tripping in 25°C still air.
- I_{trip}= Trip current: minimum current at which the device will trip in 25°C still air.
- V_{max}= Maximum voltage device can withstand without damage at rated current (I_{max})
- I_{max}= Maximum fault current device can withstand without damage at rated voltage
- Pd typ.= Typical power dissipated from device when in the tripped state at 23°C still air.
- R_{min}= Minimum resistance of device in initial (un-soldered) state.
- R_{max}= Maximum resistance of device in initial (un-soldered) state.

Test Procedures and Requirement

Items	Test Conditions	Accept/Reject Criteria
Resistance	In still air @25°C	R min ≤ R ≤ R max
Time to Trip	Specified current, V max , 25°C	T ≤ max. Time to trip (T trip)
Hold Current	30 min, at I _{hold}	No trip
Trip Cycle Life	V max , I max , 100 cycle	No arcing or burning
Trip Endurance	V max , 24hours	No arcing or burning

Thermal Derating Chart – Ihold

Part Number	Ambient Operation Temperature									
	-40°C	-20°C	0°C	25°C	30°C	40°C	50°C	60°C	70°C	85°C
FTR600-110	0.160	0.152	0.131	0.110	0.100	0.091	0.080	0.070	0.061	0.046
FTR600-150	0.218	0.207	0.179	0.150	0.137	0.125	0.110	0.096	0.083	0.063
FTR600-160	0.232	0.221	0.190	0.160	0.146	0.133	0.117	0.102	0.088	0.067

Dimensions

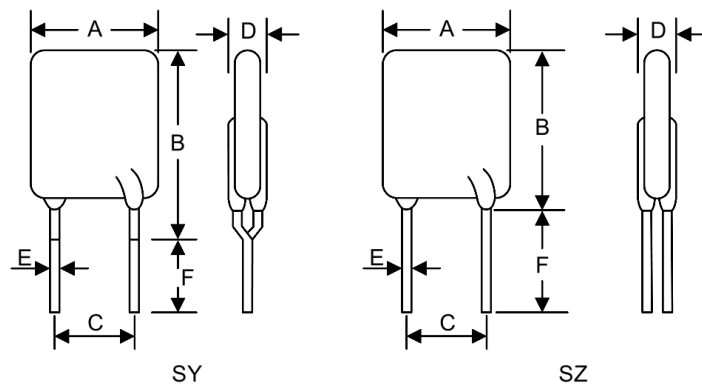

Part Number	Dimensions (mm)						Style.
	A	B	C	D	E	F	
	Max.	Max.	±0.6	Max.	Typ.	Min.	
FTR600-110	15	18	5.1	6.5	0.6	4.6/7.6	SY/SZ
FTR600-150	15	18	5.1	6.5	0.6	4.6/7.6	SY/SZ
FTR600-160	15	18	5.1	6.5	0.6	4.6/7.6	SY/SZ

Marking Code

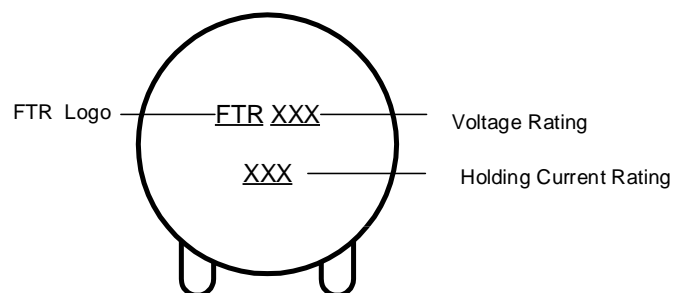

Recommended Soldering Conditions

Wave Soldering Recommendation Parameters

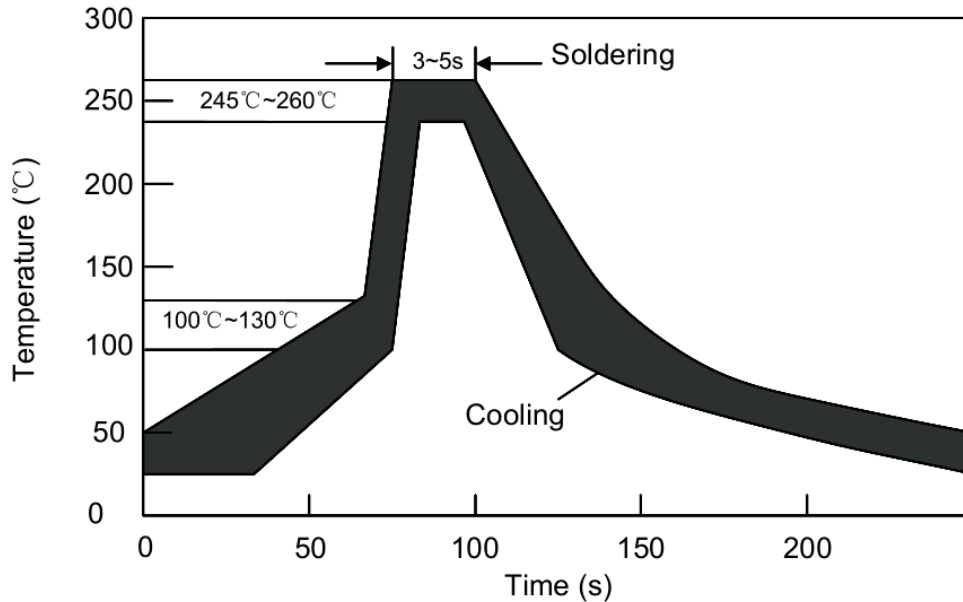

Items	Conditions
Pre-Heating Zone	Refer to the condition recommended by the flux manufacturer. Max. ramping rate should not exceed 4°C/Sec.
Soldering Zone	Max. solder temperature should not exceed 260°C Time within 5°C of actual Max. solder temperature within 3 - 5 seconds Total time from 25°C room to Max. solder temperature within 5 minutes including Pre-Heating time
Cooling Zone	Cooling by natural convection in air. Max. ramping down rate should not exceed 6°C/Sec.

Manual Soldering Recommendation Parameters

Items	Conditions
Soldering condition	The highest power of the manual soldering iron should be 30W or less, soldering temperature should not be higher than 280°C.
Soldering time	The soldering time should be kept within 3 seconds, otherwise it might cause insulation layer cracking, and increased part resistance.
Soldering position	The distance on the leads between the soldering point and bottom of the PPTC body should be equal or greater than 4mm.
Other	The soldering iron should not contact the PPTC body except the leads. If the soldering conditions are kept to lower temperature, less time and larger distance, the outcome of the soldering will be better.

Partnumber code

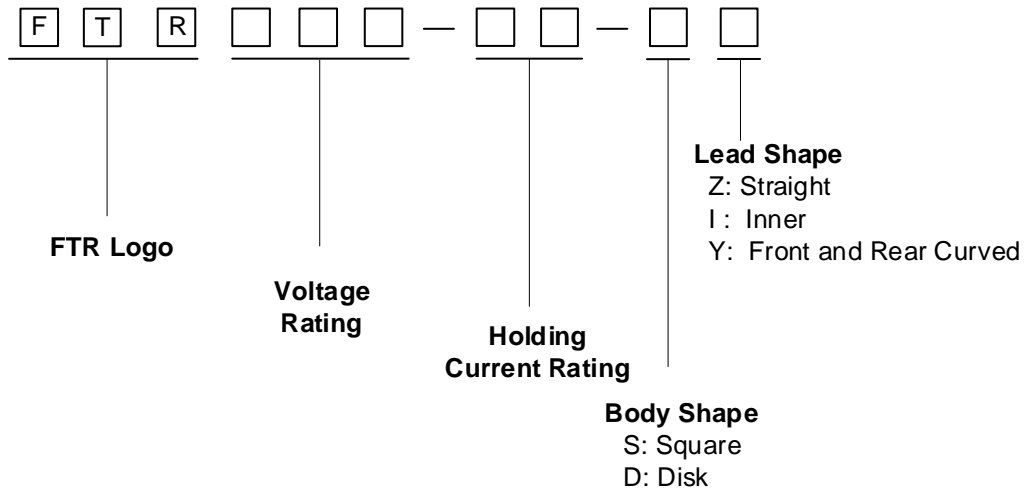

Environmental Specifications

Operating / Storage temperature	-40°C to +85°C
Maximum Device Surface Temperature in Tripped State	125°C
Passive Aging	+85°C, 1000 hours ±5% typical resistance change
Humidity Aging	+85°C, 85%RH, 1000 hours ±5% typical resistance change
Thermal Shock	+85°C to -40°C 10 times 30% typical resistance change
Solvent Resistance	MIL-STD-202, Method 215 No change
Moisture Level Sensitivity	Level 1, J-STD-020

Mechanical Specifications

Tensile strength	1.0Kgf, 10 seconds, No visible damage
Bending strength	0.5Kgf, 90°, 3 times, No visible damage
Vibration	Freq: 10-55Hz, Amp: 0.75mm, 1min; No visible damage

Packaging

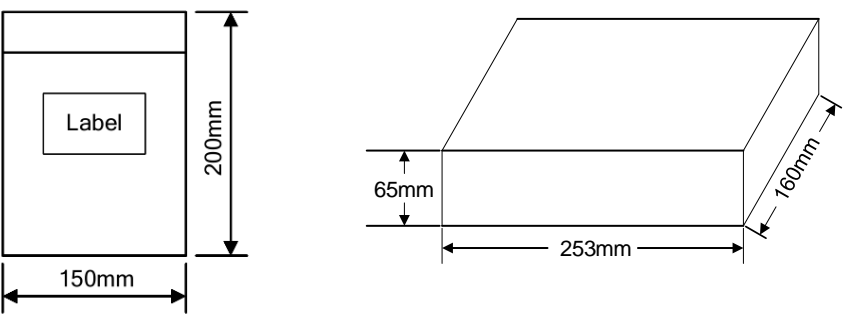
<p>Bag</p> 	Part Number	Quantity
	FTR600-110	500pcs/bag 1000pcs/box
	FTR600-150	
	FTR600-160	