

## Transient Voltage Suppressors (TVS) Data Sheet

### Features

- Glass passivated junction
- Low zener impedance
- Excellent clamping capability
- 600W peak pulse power capability at 10/1000µs waveform, repetition rate (duty cycle):0.01%
- Fast response time
- Typical  $I_R$  less than 1µA above 11V.
- Plastic package has underwriters laboratory flammability 94V-0
- Meets MSL level 1, per J-STD-020.
- AEC-Q101 Qualified

### Mechanical Data

- Case: JEDEC DO-214AAMoulded plastic
- Terminal:solderplated, solderable per MIL-STD-750, Method 2026
- Polarity: Color band denotes cathode except bi-directional models
- Mounting Position: Any

### Applications

- I/O interface
- AC/DC power supply
- Low frequency signal transmission line (RS232, RS485, etc.)

### Maximum Ratings and Characteristics

Ratings at 25°C ambient temperature unless otherwise specified.

Rating	Symbol	Value	Units
Peak pulse power dissipation at 10/1000µs waveform (Note1, Fig.1)	$P_{PPM}$	Minimum 600	Watts
Peak pulse current of at 10/1000µs waveform (Note 1, Fig.3)	$I_{PPM}$	See Table	Amps
Steady state power dissipation at $T_L=75^\circ\text{C}$ (Fig.4)	$P_{M(AV)}$	5.0	Watts
Peak forward surge current, 8.3ms single half sine-wave superimposed on rated load, (JEDEC Method) (Note2)	$I_{FSM}$	100	Amps
Operating junction and Storage Temperature Range.	$T_J, T_{STG}$	-55 to +150	°C
Typical thermal resistance junction to lead	$R_{\theta JL}$	20	°C/W
Typical thermal resistance junction to ambient	$R_{\theta JA}$	100	°C/W

Notes: 1. Non-repetitive current pulse, per Fig.3 and derated above  $T_A=25^\circ\text{C}$  per Fig.2.

2. 8.3ms single half sine-wave, or equivalent square wave, duty cycle=4 pulses per minutes maximum.

## Dimensions (DO-214AA/SMB)

Symbol	Millimeters		Inches	
	Min.	Max.	Min.	Max.
L	4.06	4.75	0.160	0.187
D	3.30	3.94	0.130	0.155
D1	1.95	2.20	0.077	0.086
T	5.18	5.59	0.204	0.220
T1	0.76	1.52	0.030	0.060
d	-	0.203	-	0.008
H	1.99	2.61	0.078	0.103

## Electrical Characteristics (T<sub>A</sub>=25°C)

Part Number		Device Marking Code		Reverse Stand-Off Voltage	Breakdown Voltage @I <sub>T</sub>	Test Current	Maximum Clamping Voltage @I <sub>PP</sub>	Peak Pulse Current	Reverse Leakage @V <sub>RWM</sub>
Unidirectional	Bidirectional	UNI	BI	V <sub>RWM</sub> (V)	V <sub>BR</sub> (V)	I <sub>T</sub> (mA)	V <sub>C</sub> (V)	I <sub>PP</sub> (A)	I <sub>R</sub> (μA)
SMBJ5.0A-AR	SMBJ5.0CA-AR	KE	AE	5.0	6.4~7.0	10	9.2	65.2	800
SMBJ6.0A-AR	SMBJ6.0CA-AR	KG	AG	6.0	6.7~7.4	10	10.3	58.3	800
SMBJ6.5A-AR	SMBJ6.5CA-AR	KK	AK	6.5	7.2~8.0	10	11.2	53.57	500
SMBJ7.0A-AR	SMBJ7.0CA-AR	KM	AM	7.0	7.8~8.6	10	12.0	50.0	200
SMBJ7.5A-AR	SMBJ7.5CA-AR	KP	AP	7.5	8.3~9.2	1	12.9	46.5	100
SMBJ8.0A-AR	SMBJ8.0CA-AR	KR	AR	8.0	8.9~9.8	1	13.6	44.1	50
SMBJ8.5A-AR	SMBJ8.5CA-AR	KT	AT	8.5	9.4~10.4	1	14.4	41.7	10
SMBJ9.0A-AR	SMBJ9.0CA-AR	KV	AV	9.0	10.0~11.0	1	15.4	39.0	5
SMBJ10A-AR	SMBJ10CA-AR	KX	AX	10.0	11.1~12.3	1	17.0	35.3	5
SMBJ11A-AR	SMBJ11CA-AR	KZ	AZ	11.0	12.2~13.5	1	18.2	33.0	1
SMBJ12A-AR	SMBJ12CA-AR	LE	BE	12.0	13.3~14.7	1	19.9	30.2	1
SMBJ13A-AR	SMBJ13CA-AR	LG	BG	13.0	14.4~15.9	1	21.5	28.0	1
SMBJ14A-AR	SMBJ14CA-AR	LK	BK	14.0	15.6~17.2	1	23.2	25.9	1
SMBJ15A-AR	SMBJ15CA-AR	LM	BM	15.0	16.7~18.5	1	24.4	24.6	1
SMBJ16A-AR	SMBJ16CA-AR	LP	BP	16.0	17.8~19.7	1	26.0	23.1	1
SMBJ17A-AR	SMBJ17CA-AR	LR	BR	17.0	18.9~20.9	1	27.6	21.8	1
SMBJ18A-AR	SMBJ18CA-AR	LT	BT	18.0	20.0~22.1	1	29.2	20.6	1
SMBJ19A-AR	SMBJ19CA-AR	LW	BW	19.0	21.1~23.3	1	30.8	19.5	1
SMBJ20A-AR	SMBJ20CA-AR	LV	BV	20.0	22.2~24.5	1	32.4	18.6	1
SMBJ22A-AR	SMBJ22CA-AR	LX	BX	22.0	24.4~26.9	1	35.5	16.9	1
SMBJ24A-AR	SMBJ24CA-AR	LZ	BZ	24.0	26.7~29.5	1	38.9	15.5	1
SMBJ26A-AR	SMBJ26CA-AR	ME	CE	26.0	28.9~31.9	1	42.1	14.3	1

## Electrical Characteristics (T<sub>A</sub>=25°C)

Part Number		Device Marking Code		Reverse Stand-Off Voltage	Breakdown Voltage @I <sub>T</sub>	Test Current	Maximum Clamping Voltage @ I <sub>PP</sub>	Peak Pulse Current	Reverse Leakage @V <sub>RWM</sub>
Unidirectional	Bidirectional	UNI	BI	V <sub>RWM</sub> (V)	V <sub>BR</sub> (V)	I <sub>T</sub> (mA)	V <sub>C</sub> (V)	I <sub>PP</sub> (A)	I <sub>R</sub> (μA)
SMBJ28A-AR	SMBJ28CA-AR	MG	CG	28.0	31.1~34.4	1	45.4	13.3	1
SMBJ30A-AR	SMBJ30CA-AR	MK	CK	30.0	33.3~36.8	1	48.4	12.4	1
SMBJ33A-AR	SMBJ33CA-AR	MM	CM	33.0	36.7~40.6	1	53.3	11.3	1
SMBJ36A-AR	SMBJ36CA-AR	MP	AP	36.0	40.0~44.2	1	58.1	10.4	1
SMBJ40A-AR	SMBJ40CA-AR	MR	CR	40.0	44.4~49.1	1	64.5	9.3	1
SMBJ43A-AR	SMBJ43CA-AR	MT	CT	43.0	47.8~52.8	1	69.4	8.7	1
SMBJ45A-AR	SMBJ45CA-AR	MV	CV	45.0	50.0~55.3	1	72.7	8.3	1
SMBJ48A-AR	SMBJ48CA-AR	MX	CX	48.0	53.3~58.9	1	77.4	7.8	1
SMBJ51A-AR	SMBJ51CA-AR	MZ	CZ	51.0	56.7~62.7	1	82.4	7.3	1
SMBJ54A-AR	SMBJ54CA-AR	NE	DE	54.0	60.0~66.3	1	87.1	6.9	1
SMBJ58A-AR	SMBJ58CA-AR	NG	DG	58.0	64.4~71.2	1	93.6	6.5	1
SMBJ60A-AR	SMBJ60CA-AR	NK	DK	60.0	66.7~73.7	1	96.8	6.2	1
SMBJ64A-AR	SMBJ64CA-AR	NM	DM	64.0	71.1~78.6	1	103.0	5.9	1
SMBJ70A-AR	SMBJ70CA-AR	NP	DP	70.0	77.8~86.0	1	113.0	5.3	1
SMBJ75A-AR	SMBJ75CA-AR	NR	DR	75.0	83.3~92.1	1	121.0	5.0	1
SMBJ78A-AR	SMBJ78CA-AR	NT	DT	78.0	86.7~95.8	1	126.0	4.8	1
SMBJ80A-AR	SMBJ80CA-AR	NW	DW	80.0	88.8~97.6	1	129.6	4.6	1
SMBJ85A-AR	SMBJ85CA-AR	NV	DV	85.0	94.4~104	1	137.0	4.4	1
SMBJ90A-AR	SMBJ90CA-AR	NX	DX	90.0	100~111	1	146.0	4.1	1
SMBJ100A-AR	SMBJ100CA-AR	NZ	DZ	100.0	111~123	1	162.0	3.7	1
SMBJ110A-AR	SMBJ110CA-AR	PE	FE	110.0	122~135	1	177.0	3.4	1
SMBJ120A-AR	SMBJ120CA-AR	PG	FG	120.0	133~147	1	193.0	3.2	1
SMBJ130A-AR	SMBJ130CA-AR	PK	FK	130.0	144~159	1	209.0	2.9	1
SMBJ140A-AR	SMBJ140CA-AR	PL	FL	140.0	155~171	1	227.0	2.7	1
SMBJ150A-AR	SMBJ150CA-AR	PM	FM	150.0	167~185	1	243.0	2.5	1
SMBJ160A-AR	SMBJ160CA-AR	PP	FP	160.0	178~197	1	259.0	2.3	1
SMBJ170A-AR	SMBJ170CA-AR	PR	FR	170.0	189~209	1	275.0	2.2	1
SMBJ180A-AR	SMBJ180CA-AR	PT	FT	180.0	200~220	1	291.0	2.1	1
SMBJ190A-AR	SMBJ190CA-AR	PU	FU	190.0	211~232	1	308.0	2.0	1
SMBJ200A-AR	SMBJ200CA-AR	PV	FV	200.0	224~247	1	324.0	1.9	1
SMBJ220A-AR	SMBJ220CA-AR	PX	FX	220.0	246~272	1	356.0	1.7	1
SMBJ250A-AR	SMBJ250CA-AR	PZ	FZ	250.0	279~309	1	405.0	1.5	1
SMBJ300A-AR	SMBJ300CA-AR	QE	GE	300.0	335~371	1	486.0	1.3	1
SMBJ350A-AR	SMBJ350CA-AR	QG	GG	350.0	391~432	1	567.0	1.1	1
SMBJ400A-AR	SMBJ400CA-AR	QK	GK	400.0	447~494	1	648.0	0.9	1
SMBJ440A-AR	SMBJ440CA-AR	QM	FM	440.0	492~543	1	713.0	0.9	1

Notes: For bidirectional type having VRWM of 10V and less, the IR limit is double.

## Recommended Soldering Conditions

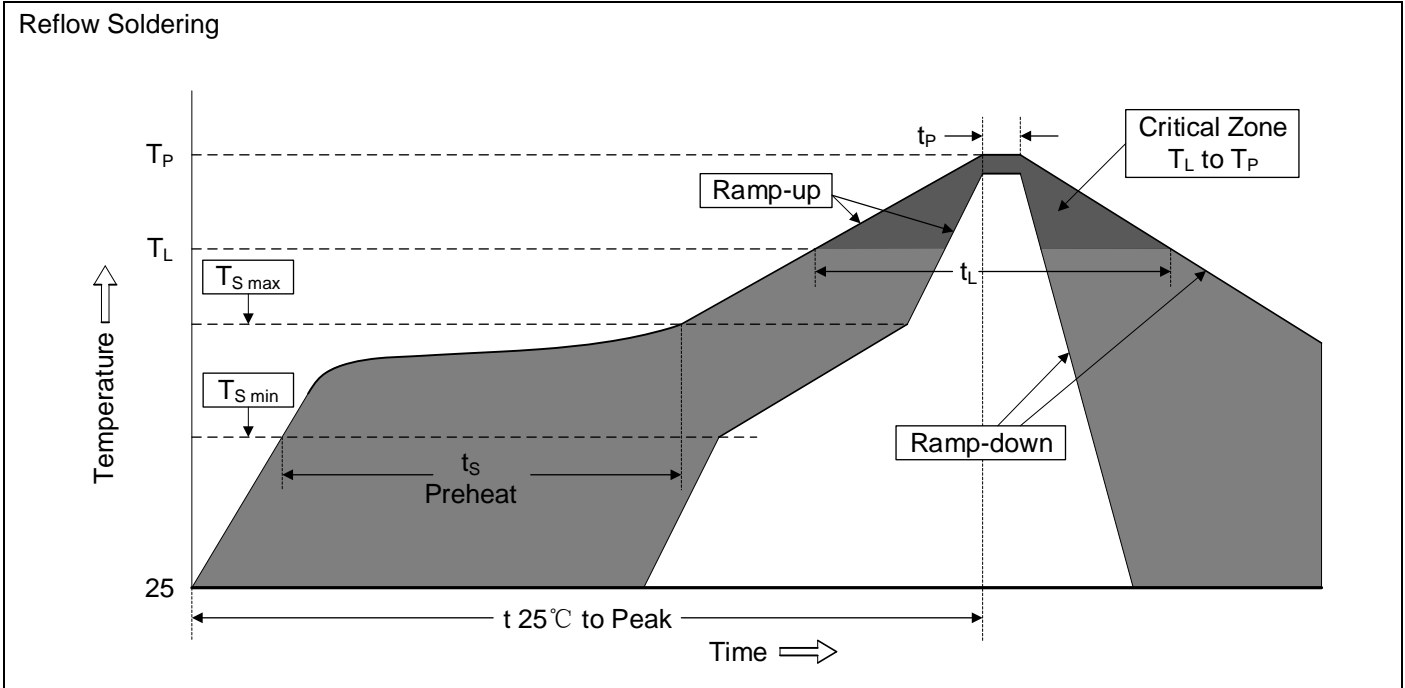

### Recommended Conditions

Profile Feature	Pb-Free Assembly
Average ramp-up rate ( $T_L$ to $T_P$ )	3°C/second max.
Preheat <ul style="list-style-type: none"> <li>-Temperature Min (<math>T_{S\ min}</math>)</li> <li>-Temperature Max (<math>T_{S\ max}</math>)</li> <li>-Time (min to max) (<math>t_s</math>)</li> </ul>	150°C 200°C 60-180 seconds
$T_{S\ max}$ to $T_L$ <ul style="list-style-type: none"> <li>-Ramp-up Rate</li> </ul>	3°C/second max.
Time maintained above: <ul style="list-style-type: none"> <li>-Temperature (<math>T_L</math>)</li> <li>-Time (<math>t_L</math>)</li> </ul>	217°C 60-150 seconds
Peak Temperature ( $T_P$ )	260°C
Time within 5°C of actual Peak Temperature ( $t_p$ )	20-40 seconds
Ramp-down Rate	6°C/second max.
Time 25°C to Peak Temperature	8 minutes max.

## Partnumbercode

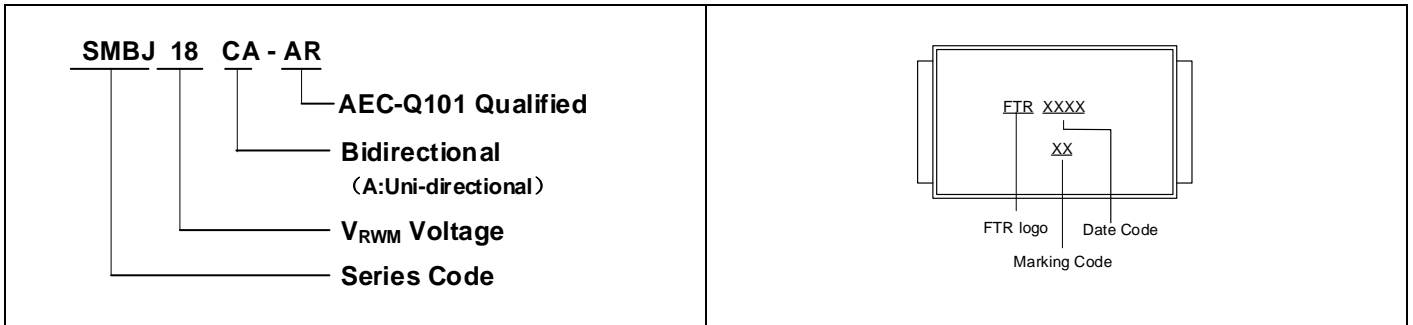

## Ratings and Characteristic Curves ( $T_A=25^\circ\text{C}$ unless otherwise noted)

Figure 1. Peak Pulse Power Rating Curve

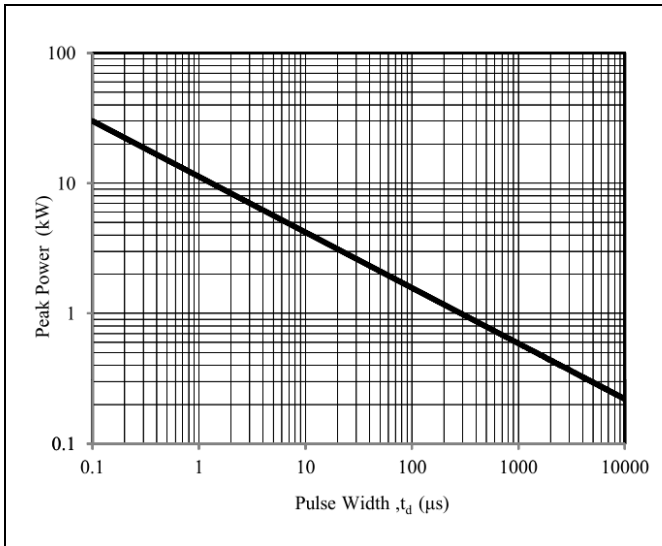

Figure 2. Pulse Derating Curve

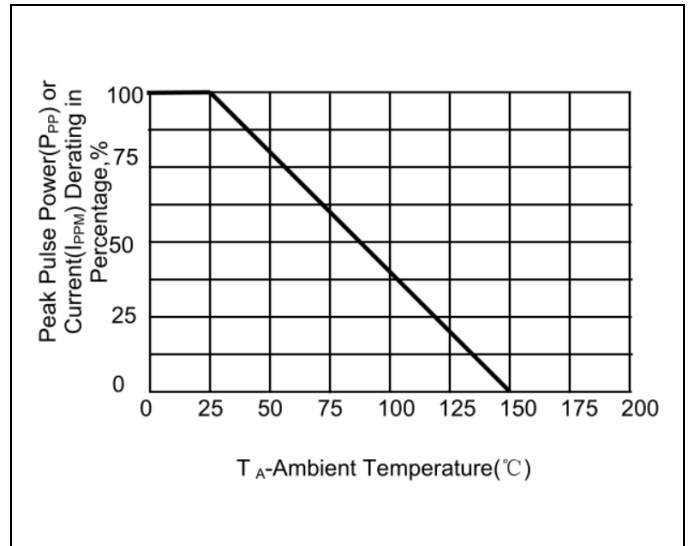

Figure 3. Pulse Waveform

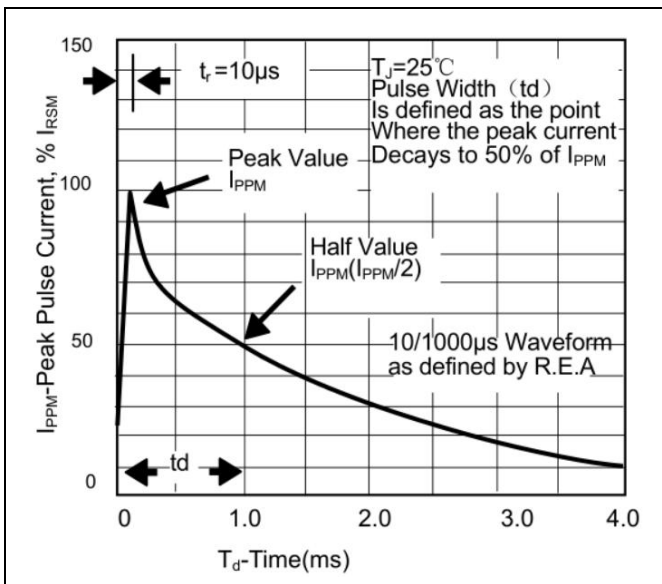
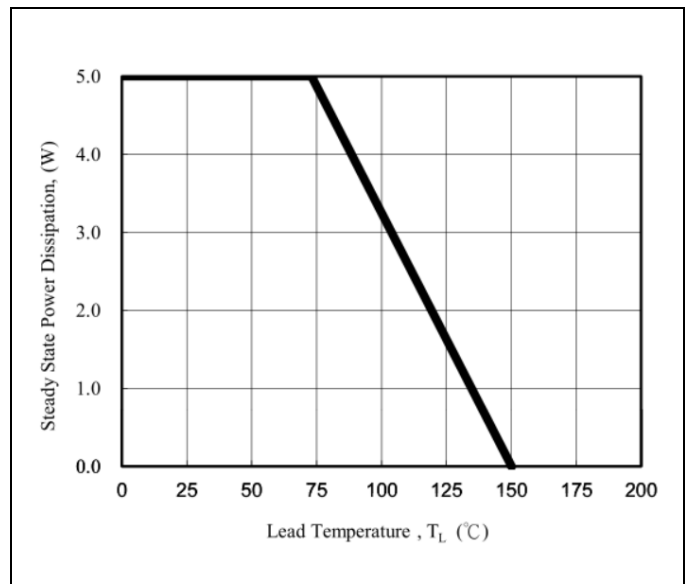
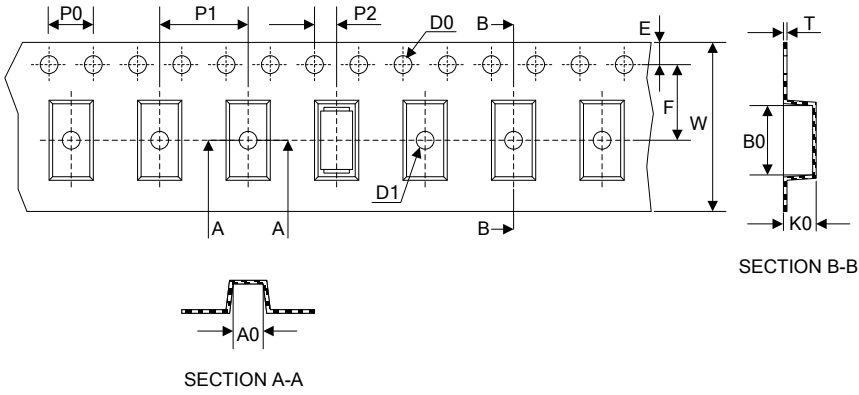
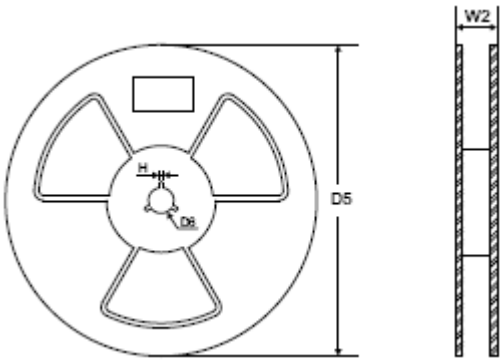

Figure 4. Steady State Power Dissipation Derating Curve



## Packaging

Tape	Symbol	Dimension (mm)
	W	12.00±0.10
	P0	4.00±0.10
	P1	8.00±0.10
	P2	2.00±0.10
	D0	Φ1.55±0.10
	D1	Φ1.5±0.10
	E	1.75±0.10
	F	5.50±0.10
	A0	3.80±0.1
	B0	5.40±0.1
	K0	2.45±0.1
	T	0.25±0.1
	<h3>Reel</h3> 	D5
D6		Φ13.5±0.5
H		2.5±1.0
W2		16.0±2.0
Quantity: 3000PCS		